



<b>Product Name</b>	GAOTek Handheld Double Clamp Digital Phase Meter – 50 Hz Signal Frequency
<b>Product SKU</b>	GAOTek-CM-113
<b>Product URL</b>	<a href="https://gaotek.com/product/gaotek-handheld-digital-double-clamp-digital-phase-meter/">https://gaotek.com/product/gaotek-handheld-digital-double-clamp-digital-phase-meter/</a>

**Contact us:**  
[sales@gaotek.com](mailto:sales@gaotek.com)

Based in New York City & Toronto, GAO Tek Inc. is ranked as one of the top ten global B2B technology suppliers. GAO ships overnight within the U.S. & Canada & provides top-notch support thanks to its 4 decades of experience.



## Contents

1 OVERVIEW.....	3
2 PRODUCT FEATURES .....	3
3 WORKING PRINCIPLE .....	4
4 TECHNICAL INDICATORS.....	5
1.Signal Generator .....	5
2. Signal Receiver .....	5
3. Machine.....	6
5 INSTRUMENT STRUCTURE .....	6
1. Machine composition .....	6
2. Signal transmitter access.....	7
3. Signal Receiver .....	8
4. Signal receivers .....	8
5. Signal output line.....	9
6 PRECAUTIONS.....	9
7 PACKING LIST .....	10



## 1 Overview

GAOTek Handheld Double Clamp Digital Phase Meter can be applied to DC systems of any voltage level, equipped with a high-precision detection clamp table, which greatly improves the detection range and anti-interference ability through efficient processing of multiple signals. By using excellent algorithm and advanced fuzzy control calculation theory, the advantages of the insulation branch detected are expressed in numerical form, which fully reflects the advantages of artificial intelligence. In addition, they have accurate judgment of the location of the receiving site. Each test can indicate the location and direction of the receiving site. The instrument takes system safety as the primary premise, according to the highest requirements of the industry standards, is tested in a reliable low-frequency signal mode, and has a large number of practical applications in the field without any impact on the system. The dc system of power plant and substation provides power for control, protection, signal and automatic device. The safe and continuous operation of dc system is of great importance to ensure power supply. Since the dc system is a floating ungrounded system, if two points are grounded, the above devices may be misused and rejected, resulting in a major accident. Therefore, when a point of grounding occurs, the receiving point should be accurately and rapidly detected while ensuring the normal power supply of the dc system, so as to eliminate the fault of grounding and avoid the possible damage caused by two points of grounding. This instrument is used to find the exact location of dc system connection- 2 of power plant and substation under the condition of continuous electricity. Various types of ground fault, can quickly find out the location, accuracy up to 100%.

## 2 Product Features:

1. The use is simple. This instrument can be directly used only by switching on the power switch, and no other key operation is needed.
2. Safety and reliability this instrument does not need to stop floating chargers and all other power supplies, with no impact on the DC system.
3. Applicable voltage level DC system 220V, 110V, 48V and 24V can be used.
4. Wide range of applications any type of power plant, substations, coal mines, chemical plants, and other power supply departments can be used.
5. Easy to carry the receiver has its battery, and no external power supply, you can carry it anywhere to find the grounding point.
6. The DC system continuously searches for the grounding point without affecting the normal operation of the system.

Based in New York City & Toronto, GAO Tek Inc. is ranked as one of the top ten global B2B technology suppliers. GAO ships overnight within the U.S. & Canada & provides top-notch support thanks to its 4 decades of experience.

- 7. It has a strong anti-interference ability and overcomes the influence of distributed capacitance of the system.
- 8. Intelligent charging management, reduces charging time and prolongs battery life.

### 3 Working Principle:

This instrument is used to find the accurate position of the DC system. grounding point in the power plant and substation under uninterrupted conditions. In principle, the instrument introduces a new detection method - waveform. analysis method. Its main characteristics and advantages are high detection. Sensitivity, strong distributed capacitance capability of the detection system, continuous electrical search, no impact on the normal operation of the system, strong anti-interference ability, safety, and reliability. Waveform analysis method is to use a specific periodic voltage signal between the DC bus and the ground to detect the current of each branch through a caliper probe, analyze and calculate the phase and phase difference between the fundamental wave and harmonics of the current signal, and then determine. Whether there is a grounding fault or grounding fault point. The instrument consists of three parts: signal generator, signal receiver and signal collector (caliper). When looking for faults in the DC system, the three must cooperate with each other. stability. The signal generator is composed of single chip microcomputer, A/D stability conversion circuit, signal amplification and filtering circuit, power amplification and isolation circuit, output feedback and protection, etc. The realization principle diagram is as follows:

## Signal generator schematic.

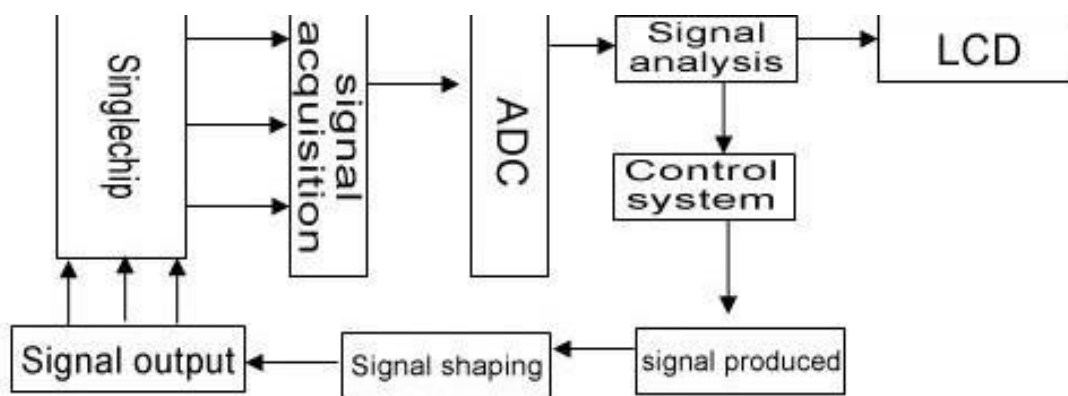

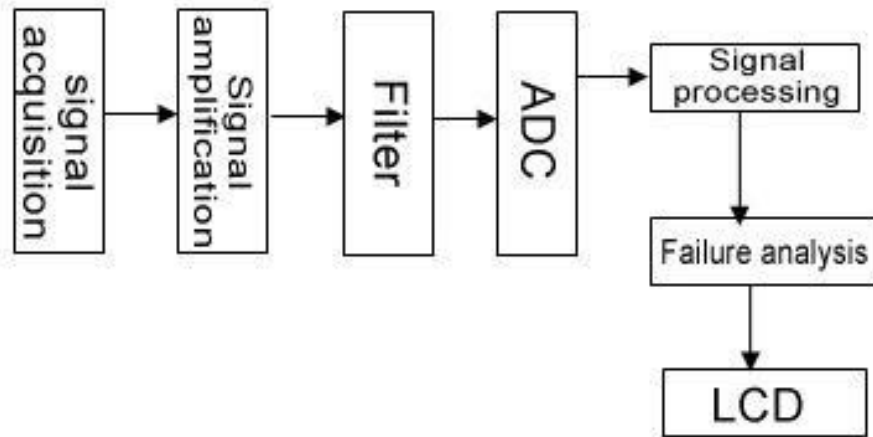

## Signal receiver schematic

### 4 Technical indicators:

#### 1.Signal Generator

1) Output signal frequency: 2.5Hz
2) Signal no-load output voltage: $\pm 20V \pm 5\%$
3) Signal voltage amplitude error: $< 5\%$
4) Signal short circuit output current: $\leq 80mA$ .
5) Output port impact resistance: 400V DC shock.
6) Power supply voltage: AC220V $\pm 10\%$
7) Voltage frequency: 50Hz $\pm 5\%$
8) Input insurance: 2A.
9) Maximum power: 3W
10) Volume: 300mm $\times$ 270mm

#### 2. Signal Receiver

1) sensitivity of signal current detection: 0.5mA
---

2) signal generator impedance: 40 k $\Omega$
3) maximum output current: 2.5ma
4) receiver display: number 0-19
5) volume: 210mm x 100mm x 32mm
6) A: jaw size: $\Phi$ 50 mm
7) B: jaw size $\Phi$ 7 mm x 9 mm

### 3. Machine

1) Detect the maximum grounding resistance: 300K $\Omega$
2) Grounding resistance measurement accuracy: 0-4.5K $\Omega$ Error $\leq$ 0.5K $\Omega$ . 4.5K $\Omega$ -300K $\Omega$ error $\leq$ 10%

## 5 Instrument structure:

### 1. Machine composition

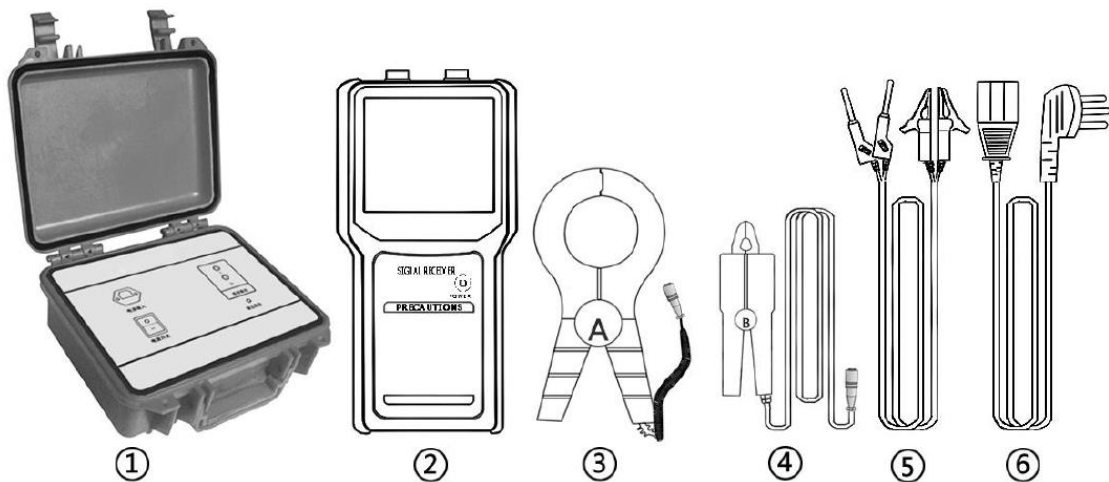

①Signal transmitter

②Signal Receiver

③A caliper

④B caliper

⑤Signal output line

⑥power cable

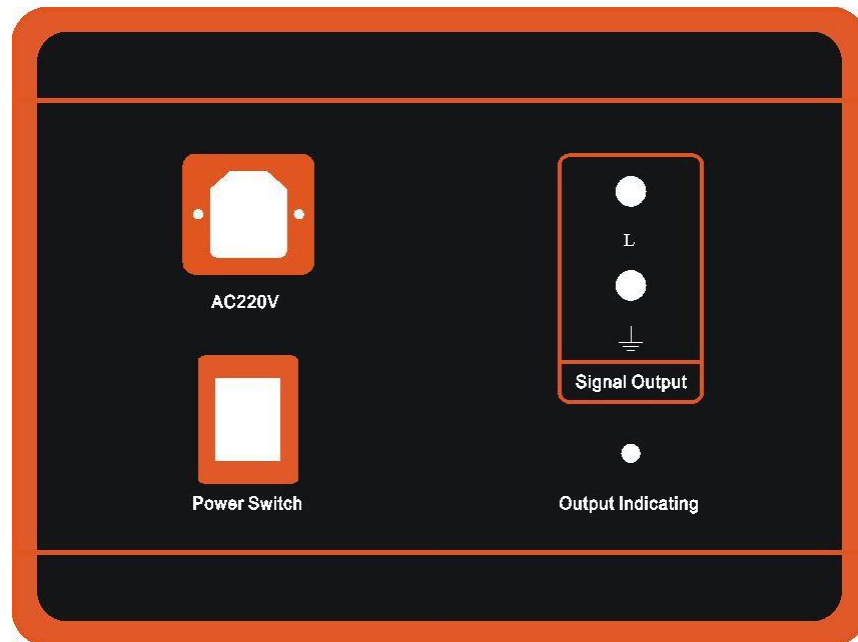

*Figure 1 panel*

- Power input : The signal transmitter needs to be connected to an external AC220V power supply. There is a fuse (2A) in the lower box of the power socket.
- Power switch : Press one end of the switch marked "I" when starting and the other end marked "O" when shutting down.
- Output Indicating : After switching on the power supply, the signal transmitter starts to output the signal. When the signal output is normal, the output indicator will flicker, indicating that there is a normal low frequency voltage output.
- Signal output: Signal output port. When used, the output lead is inserted and the signal is output through it.

## 2. Signal transmitter access:

The signal output lead is inserted into the signal transmitter, the red clip.

clip bus bar and the black clip grounding wire. When the signal transmitter is properly connected, turn on the signal transmitter power switch. According to the dc system ground fault, the signal transmitter is connected to the bus and ground line near the battery output.

Branches with grounding but far loop direction have been detected. To improve detection accuracy, signal transmitter can be connected to the dc exit at the beginning of the branch closer to the fault area, or on the dc small bus under the loop. When detecting, the signal transmitter should always be connected to the power end of dc branch, while the fault detector and clamp table should. always be detected at the load end of dc branch.

### 3. Signal Receiver:

Figure 2 panel diagram

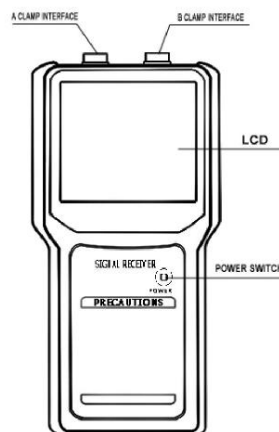

- A clamp interface : The receiving clamp marked "A" is A large caliper.
- B clamp interface : The receiving clamp marked "B" is a small caliper.
- LCD: Dot matrix LCD display.
- Power switch : Press the "ON/OFF" button to turn it on or off.

### 4. Signal receivers:

Calipers are used to clamp the main circuit connected with the faulty bus, and the LCD display is looked at separately. The insulation value is 0-19 from low to high, 01 indicates poor insulation, and 19 indicates good insulation. When the LCD displays a lower value, the fault can be identified in the main circuit, and then the calipers are respectively measured with the fault main circuit of each branch, through the LCD state to determine the fault branch, followed by analogy, the final fault branch can be found by the same method. After detecting the grounding branch, the specific grounding fault location is detected. Users can take the dichotomy to detect and locate the fault area when testing. After each test, the fault area is checked and located in the next time according to the two-point method, to





quickly detect the specific grounding fault point. Assuming that there is grounding condition in the detection of A and there is no grounding condition in the detection of B, the grounding fault point can be judged between A and B. At the same time, according to the feeder cable direction and equipment connection, each feeder entrance of the fault branch can be detected separately to find out the fault branch and further locate the fault.

The calipers used in this instrument can be used to measure the current on the bus and the current on the feeder, and the sensitivity is very high. Because of its high sensitivity, the display data of the fault detector may be unstable due to the change of magnetic flux when the caliper jitters. Therefore, the measurement should try to hold the caliper or clamp the feeder and release the hand, so that it is fixed in the test position, until the stable data is measured.

### 5. Signal output line:

The red lead is connected to the faulty busbar end. The black leads are grounded. The red plug is inserted into the "L" end of the signal transmitter, and black is inserted into the

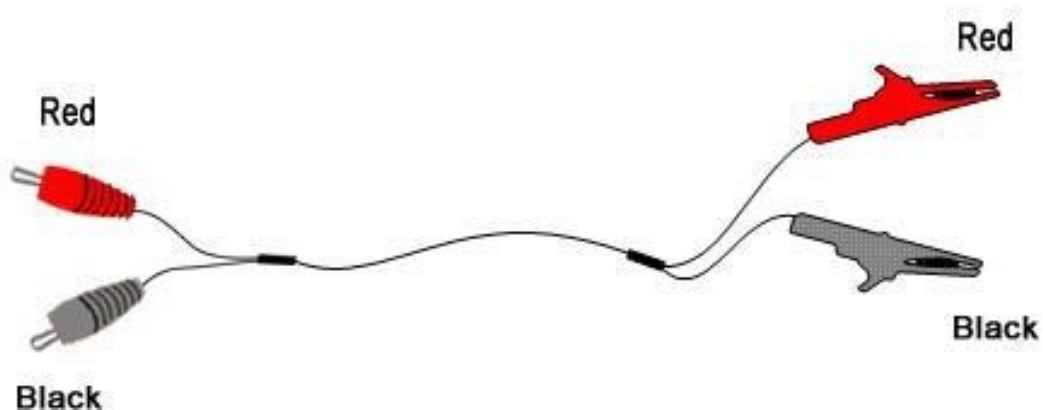

*Figure 3 signal output line*

### 6 Precautions:

1. The precision instrument of this instrument should be handled with care during transportation, use and storage. All parts should be protected from strong vibrations such as falling and falling.
2. The signal source should be added to the faulty bus and ground.
3. The clamp-type caliper of this instrument can only be used in the DC loop and cannot be connected to the AC circuit.
4. When there is no obvious grounding of each branch, it should be noted

Based in New York City & Toronto, GAO Tek Inc. is ranked as one of the top ten global B2B technology suppliers. GAO ships overnight within the U.S. & Canada & provides top-notch support thanks to its 4 decades of experience.



whether the grounding point is in the power supply part, such as battery, charger and other parts.

5. During the test, please turn off the power when the clamp and signal receivers are not in use to extend the battery life.
6. When the signal receiver is low, the battery should be replaced in time to improve the accuracy of the test.
7. Because the sensitivity of the clamp is very high, do not hold the clamp watch with your hand during the test. Keep the clamp at rest, so as not to affect the detection accuracy.

## 7 Packing list

1	Signal transmitter	1
2	Signal receiver	1
3	A clamp	1
4	A clamp	1
5	Signal output line	1
6	power cable	1
7	battery	5
8	2A fuse	2
9	Aluminum alloy box	1
10	manual	1
11	Test Report	1
12	Certificate/warranty card	1